

# Nuclear Hydrogen Production: Scoping the Safety Issues

**Satyen Baidur**

Ottawa Policy Research Associates, Inc.

<http://www.ottawapolicyresearch.ca>

Thursday, January 24, 2008

Presentation to

Canadian Nuclear Society

Ottawa Chapter



# Nuclear Hydrogen Production (NHP) Scoping the Safety Issues

***Hydrogen Use Will Rise Sharply in Fossil Fuel Sector (Alberta).  
Need for Process Heat to extract crude from Oil Sands will grow.  
Nuclear Hydrogen Production (and Heat) is Especially Attractive***

*Reduces Emissions (CO<sub>2</sub>). But:*

*Electro- Thermo-Chemical + Nuclear: Unprecedented.*

*Incremental Risk (i) Chemical Plant (SO<sub>2</sub>) (ii) Onsite storage H<sub>2</sub> ; O<sub>2</sub>*

## **Preliminary, Foresighting Analysis**

*Preliminary PSA-type Analysis of Incremental Risk:*

*(Detailed PSA-type Analysis required of Chemical Plant as well.)*

*Currently Hydrogen in Widespread use in N-plants (BWRs PWRs)*

*Can be generated in LOCA (metal-water interactions etc) Tritium*

***This Talk: Incremental Risk from generating Hydrogen  
near N-plant.***



Satyen Baindur  
Ottawa Policy Research Associates  
CNS Ottawa Chapter January 24 2008



**Before we get to a full-fledged H2E, Hydrogen Use in Fossil Fuel Industry will Rise**

**Crude Oil Quality Change**

Forsberg 2001

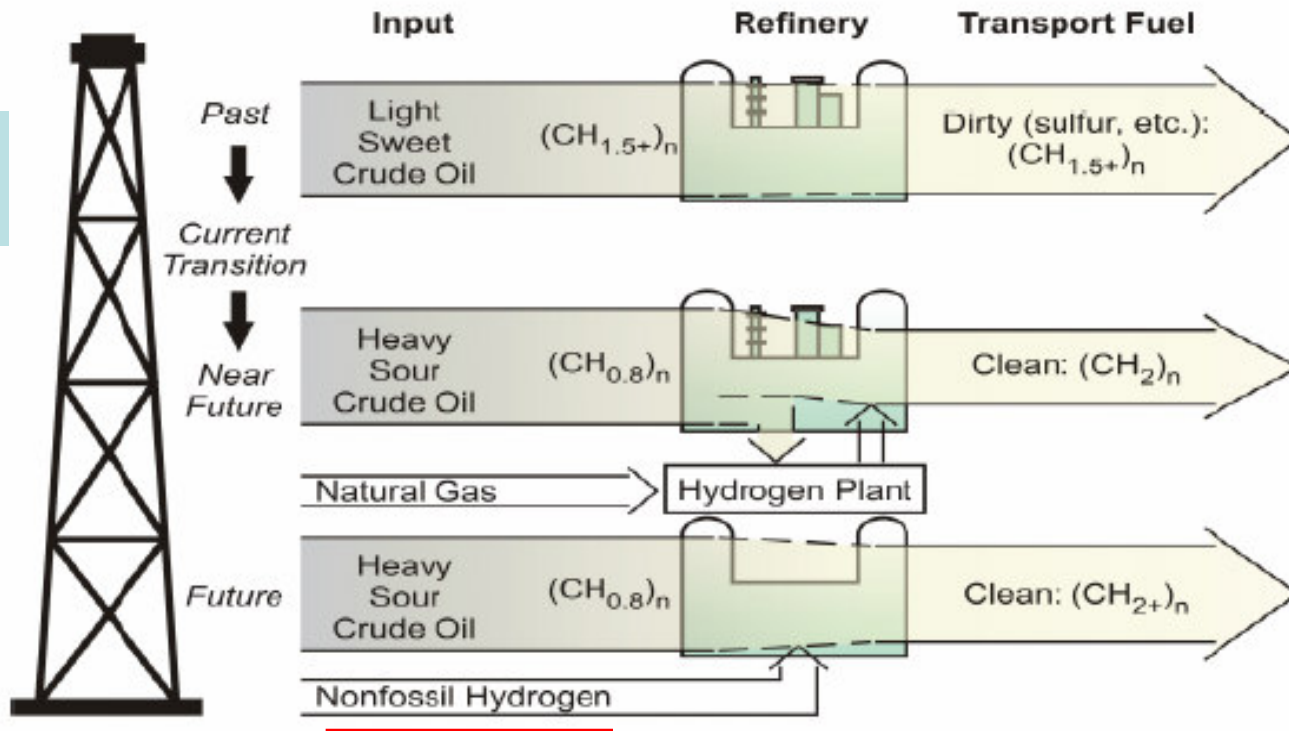

Satyen Baidur  
 Ottawa Policy Research Associates  
 CNS Ottawa Chapter January 24 2008



# Hydrogen Usage in Canada (CHA 2007)

Total Canadian Production is expected to rise from 800K tons to 2.8 M tons in 2020

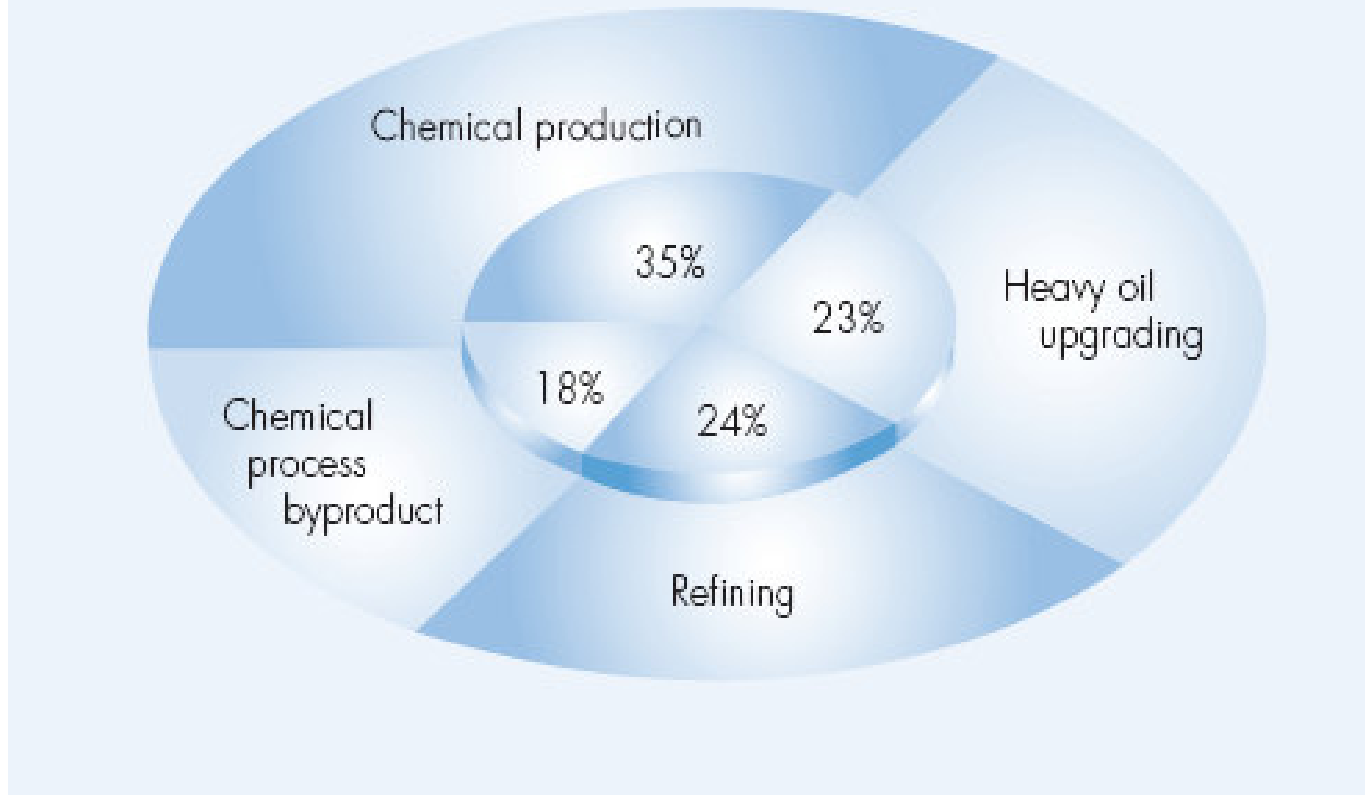

Satyen Baidur  
Ottawa Policy Research Associates  
CNS Ottawa Chapter January 24 2008



# Nuclear Hydrogen Production Canadian Developments

- **Alberta**
  - Bruce Power buys Energy Alberta Corporation November 2007
  - Strong interest from Oil Sands Industry in Nuclear Power
  - For Electricity, Process Heat **and Hydrogen**
  - Oil Sands Extraction, Coal Liquefaction, Synthetic Fuels
- **Ontario**
  - Bruce Power considering Nuclear Hydrogen Production
    - For Off-Peak Energy Utilization - announced Fall 2006.



Satyen Baidur  
Ottawa Policy Research Associates  
CNS Ottawa Chapter January 24 2008



# Hydrogen Economy: Production, Demand and Supply

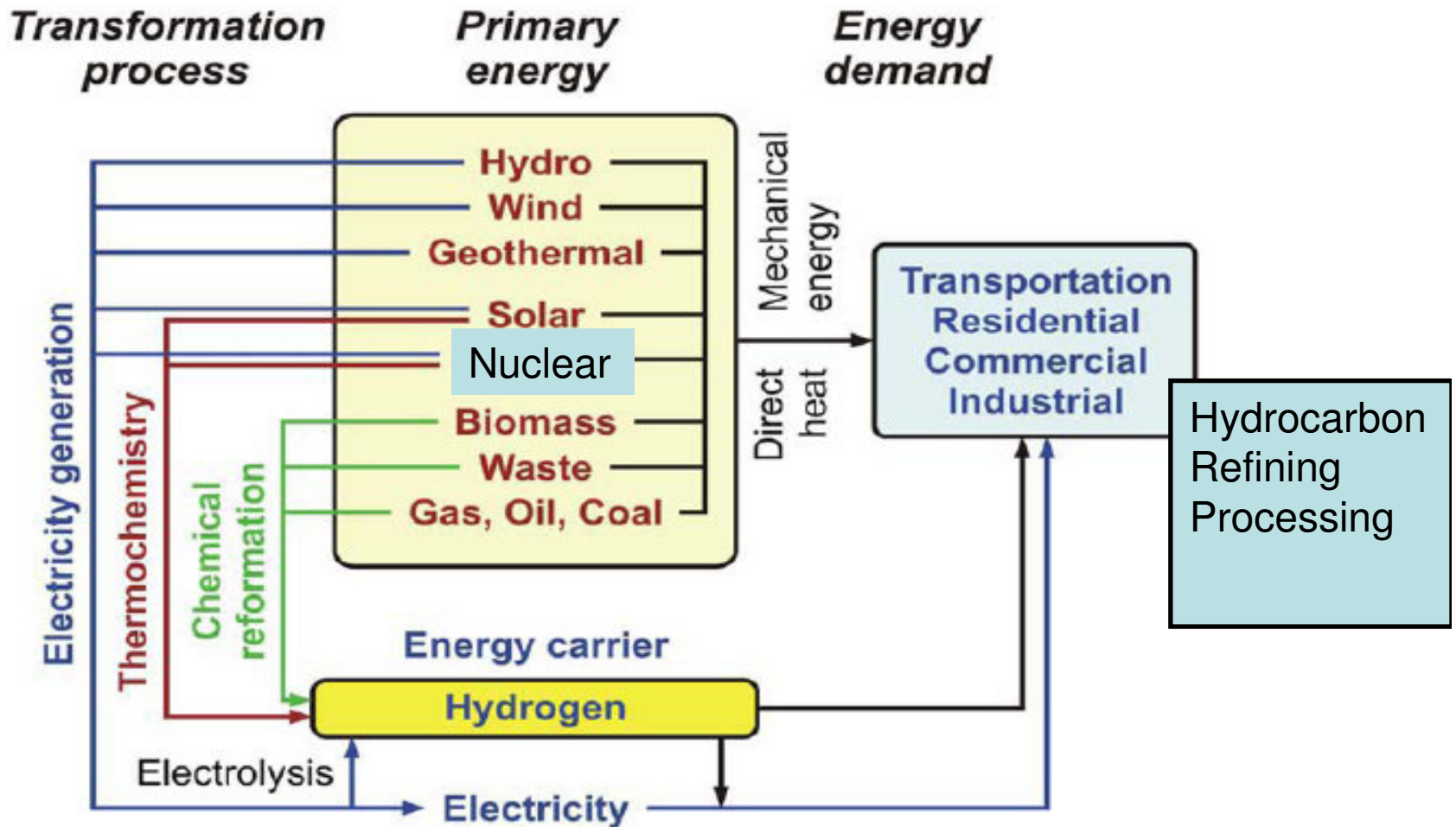

Satyen Baidur  
 Ottawa Policy Research Associates  
 CNS Ottawa Chapter January 24 2008



# Operating Ranges of Gen-IV Concepts & Hydrogen Production Technology Requirements

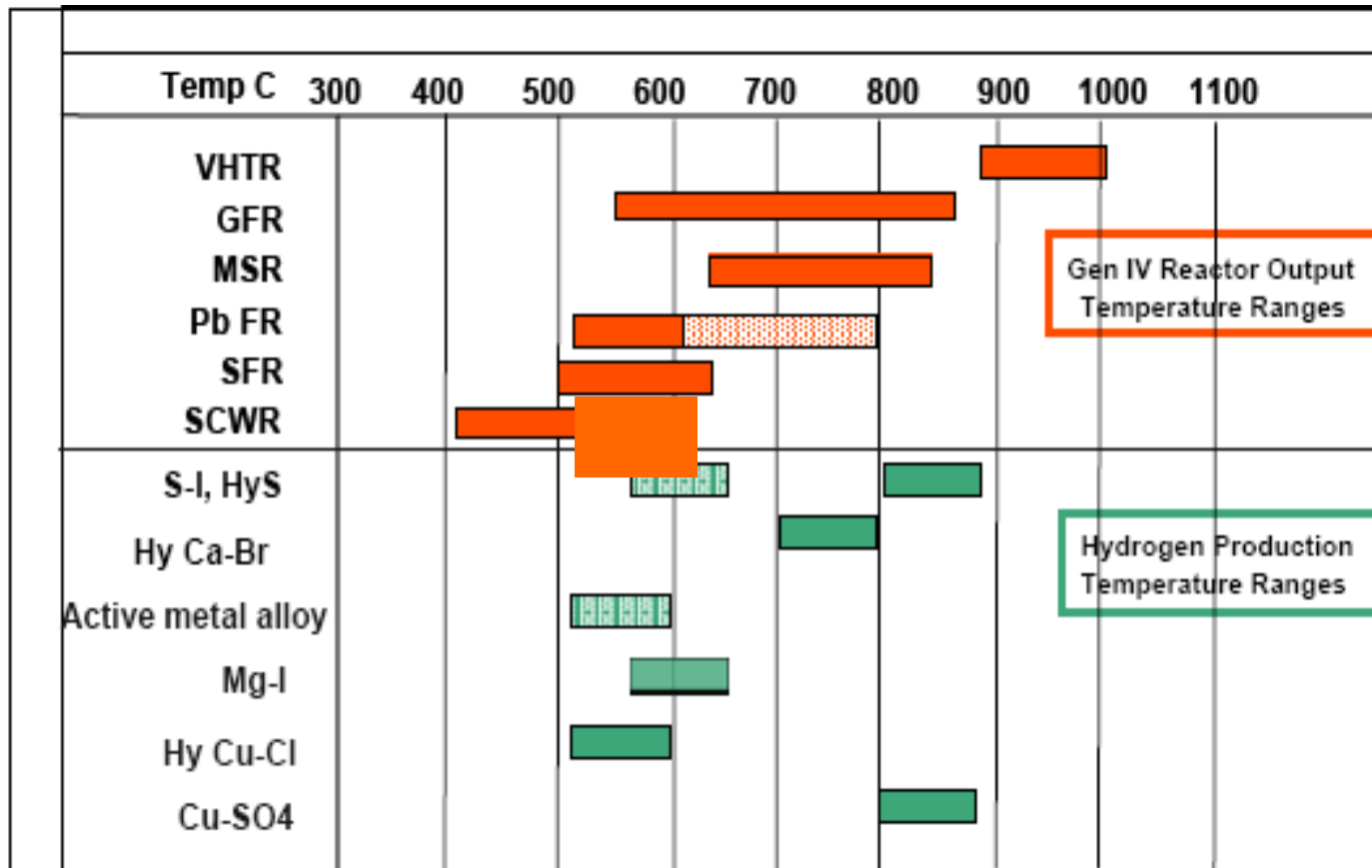

Satyen Baidur  
 Ottawa Policy Research Associates  
 CNS Ottawa Chapter January 24 2008



# The Sulphur-Iodine Cycle (US, EU, Japan)

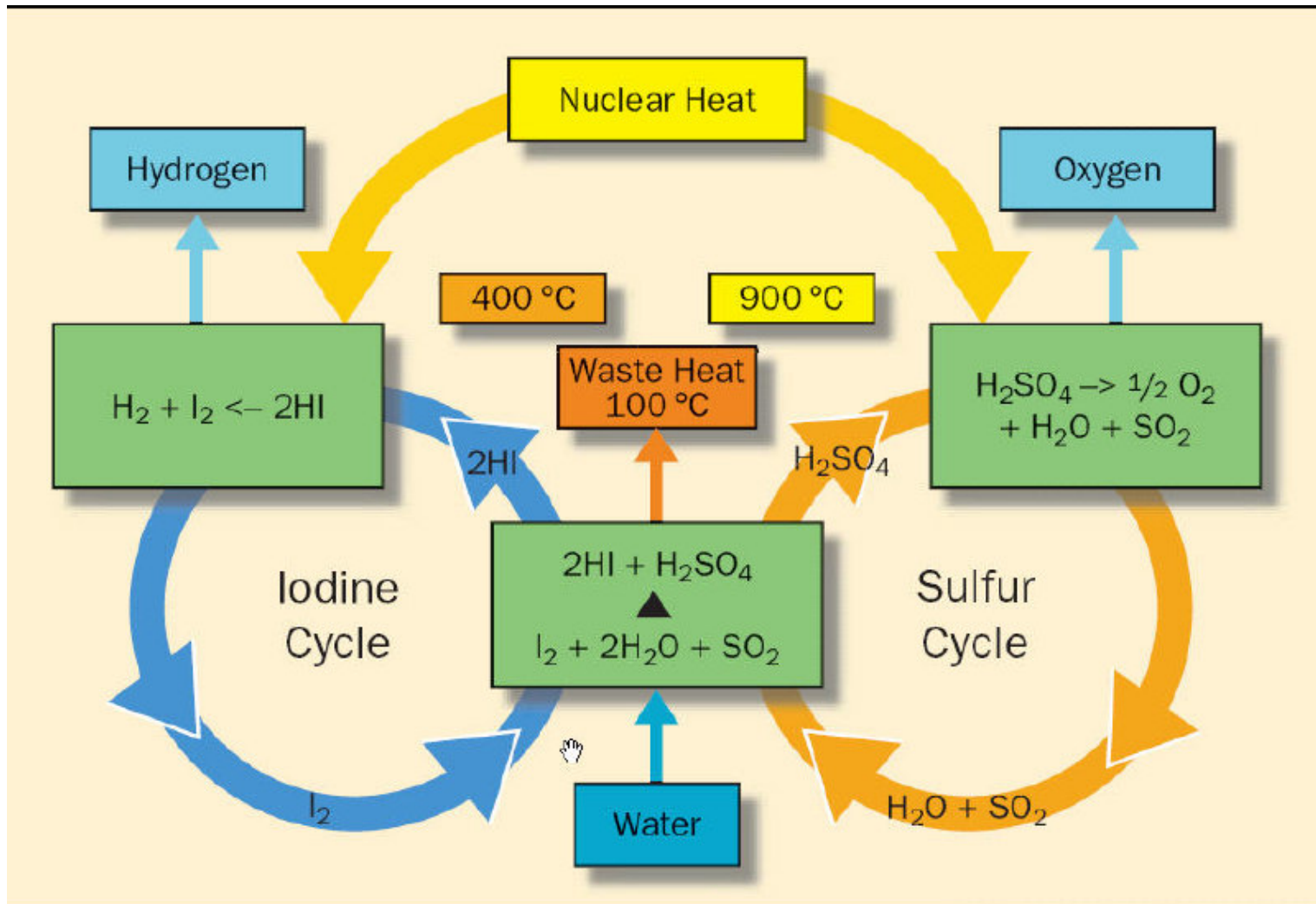

Satyen Baidur  
 Ottawa Policy Research Associates  
 CNS Ottawa Chapter January 24 2008



# The Copper-Chlorine Cycle

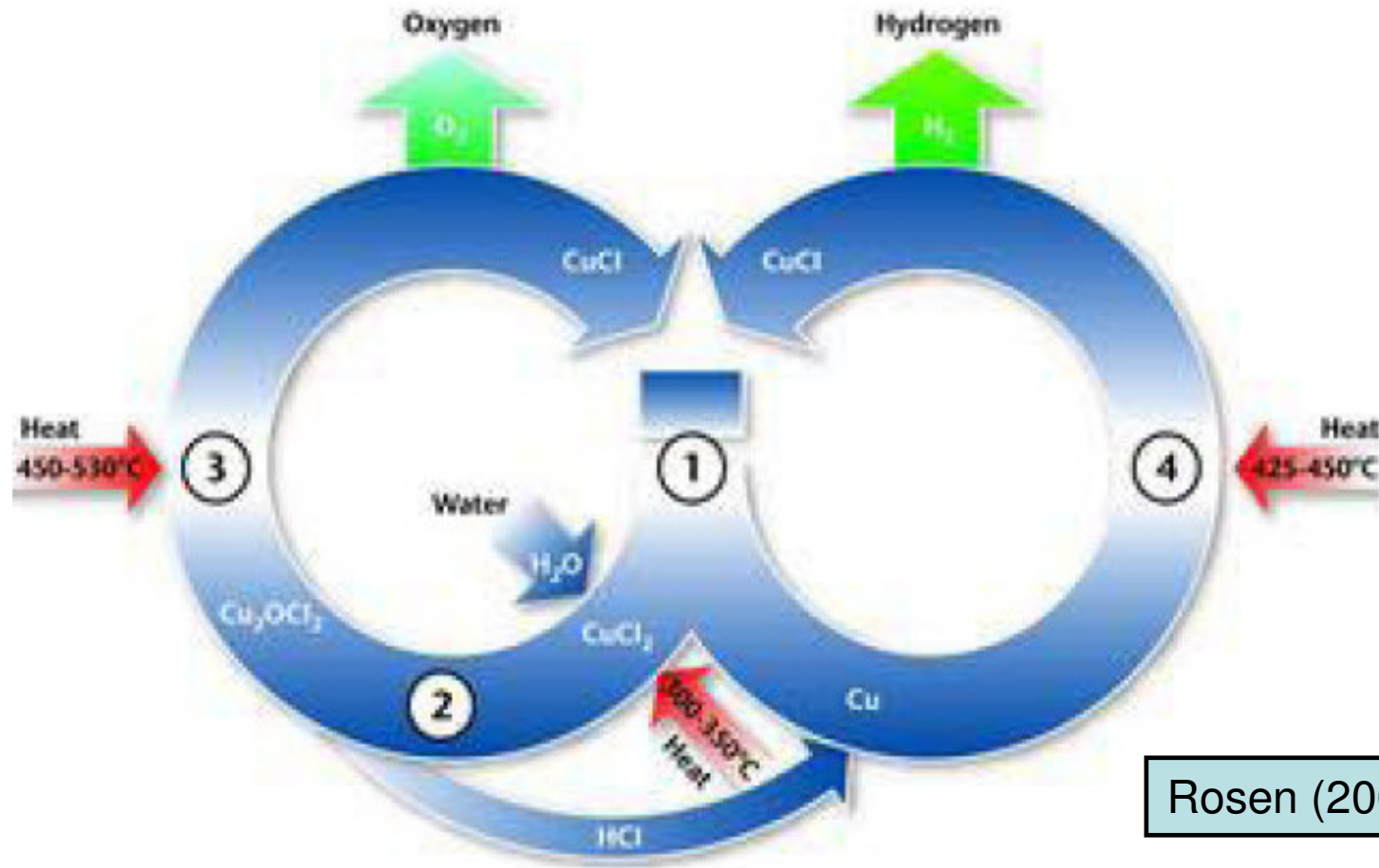

Satyen Baidur  
Ottawa Policy Research Associates  
CNS Ottawa Chapter January 24 2008



# Related Applications

## Liquid Salt as Heat Transport Fluid instead of SAGD

### Nuclear-Heated In-Situ Oil-Shale Conversion Process

#### Liquid-Salt Heat-Transport Loop

Forsberg 2007

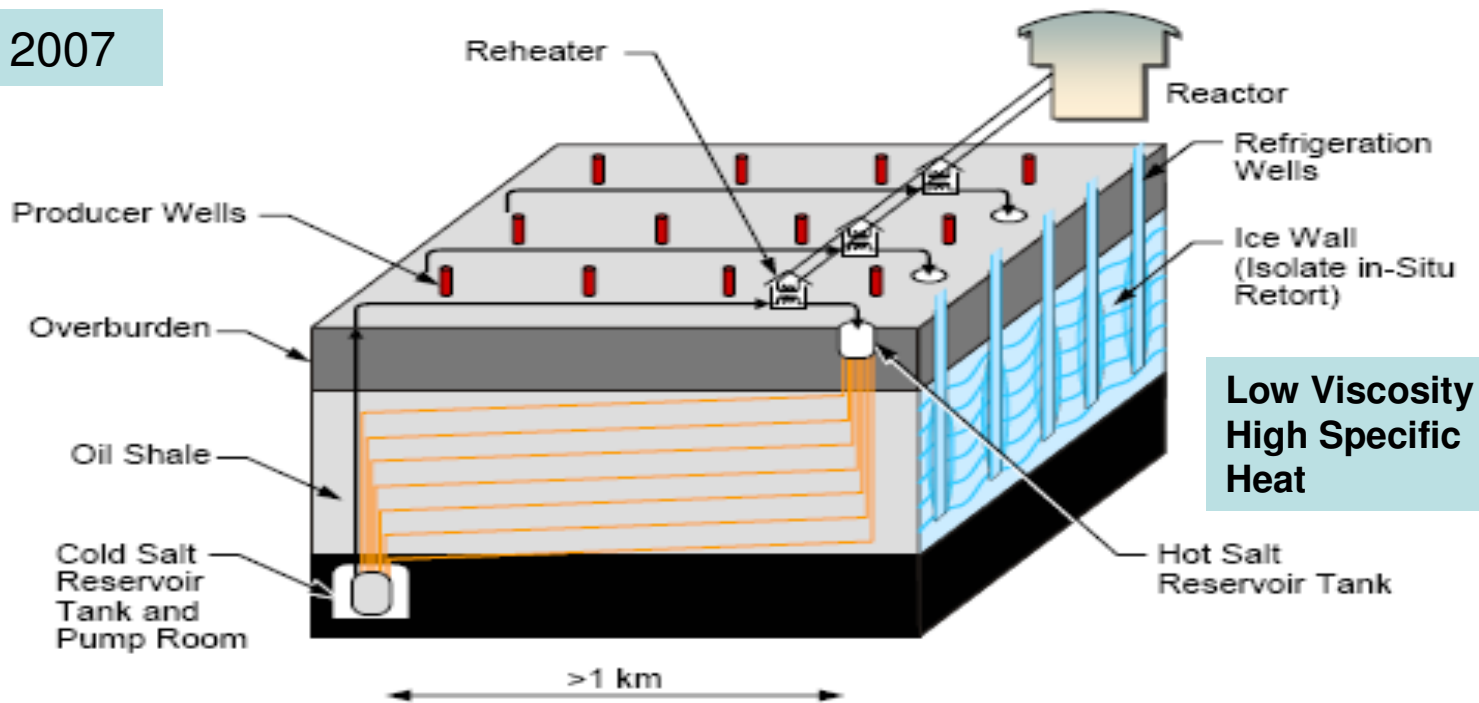

Satyen Baidur  
Ottawa Policy Research Associates  
CNS Ottawa Chapter January 24 2008



# Conceptual Schematic of a Nuclear-powered High Temperature Electrolysis Plant

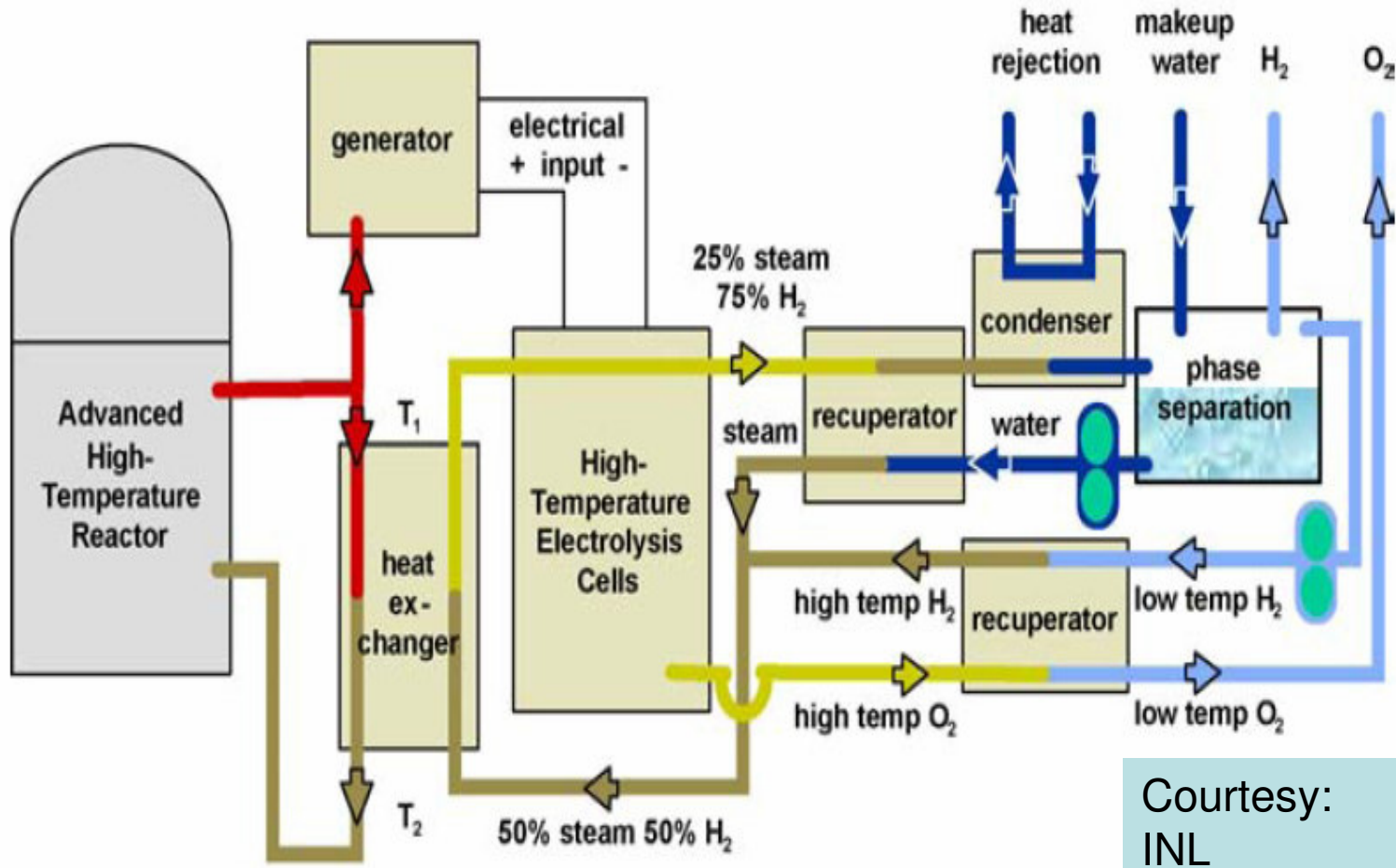

Courtesy:  
INL



Satyen Baidur  
Ottawa Policy Research Associates  
CNS Ottawa Chapter January 24 2008



# Gen-IV Reactor Outlet Temperatures Possible Non-Electric Uses

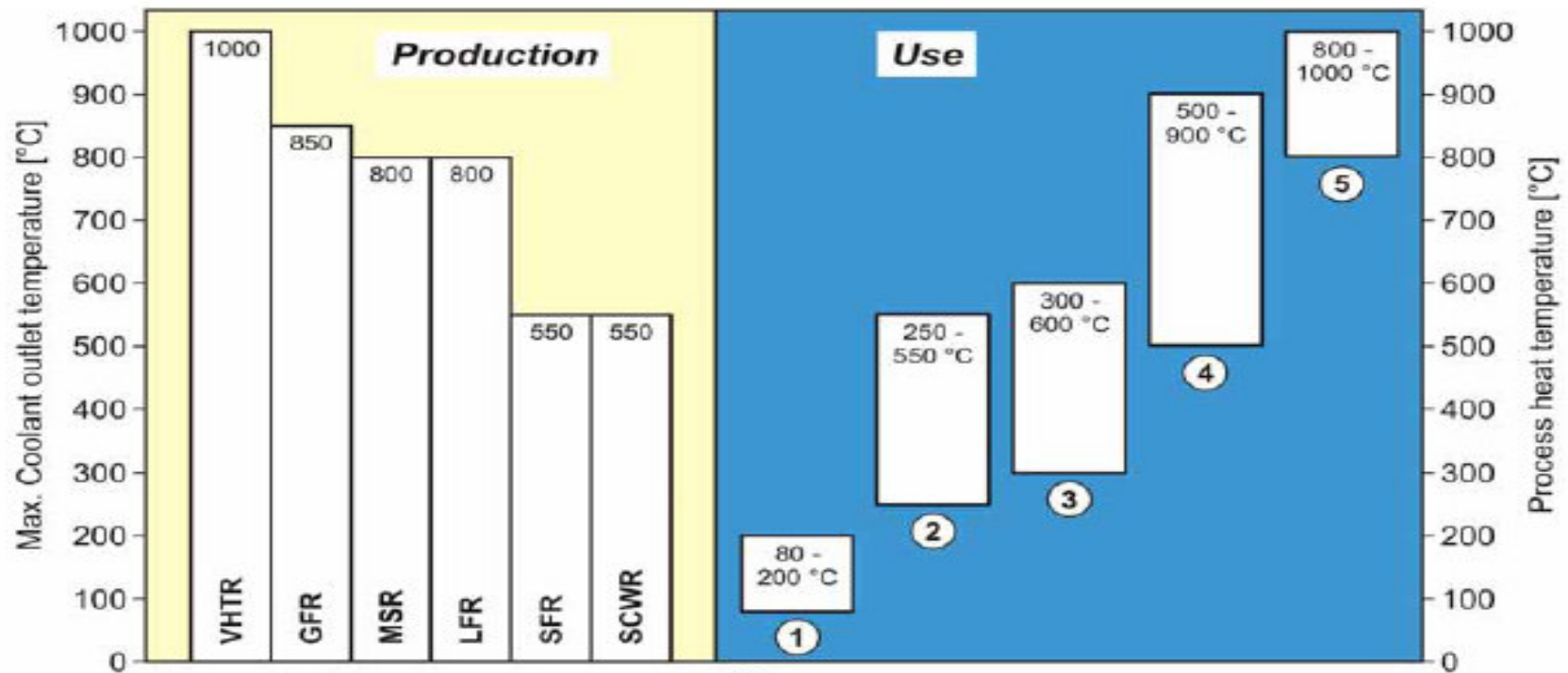

(1) District Heating, Seawater Desalination. (2) Petroleum Refining. (3) Oil Sand Processing. (4) Nuclear Steam Methane Reforming. (5) S-I Cycle, High Temperature Steam Electrolysis, Coal Gasification



Satyen Baidur  
Ottawa Policy Research Associates  
CNS Ottawa Chapter January 24 2008



# Schematic of Nuclear Reactor Coupled to Hydrogen Plant

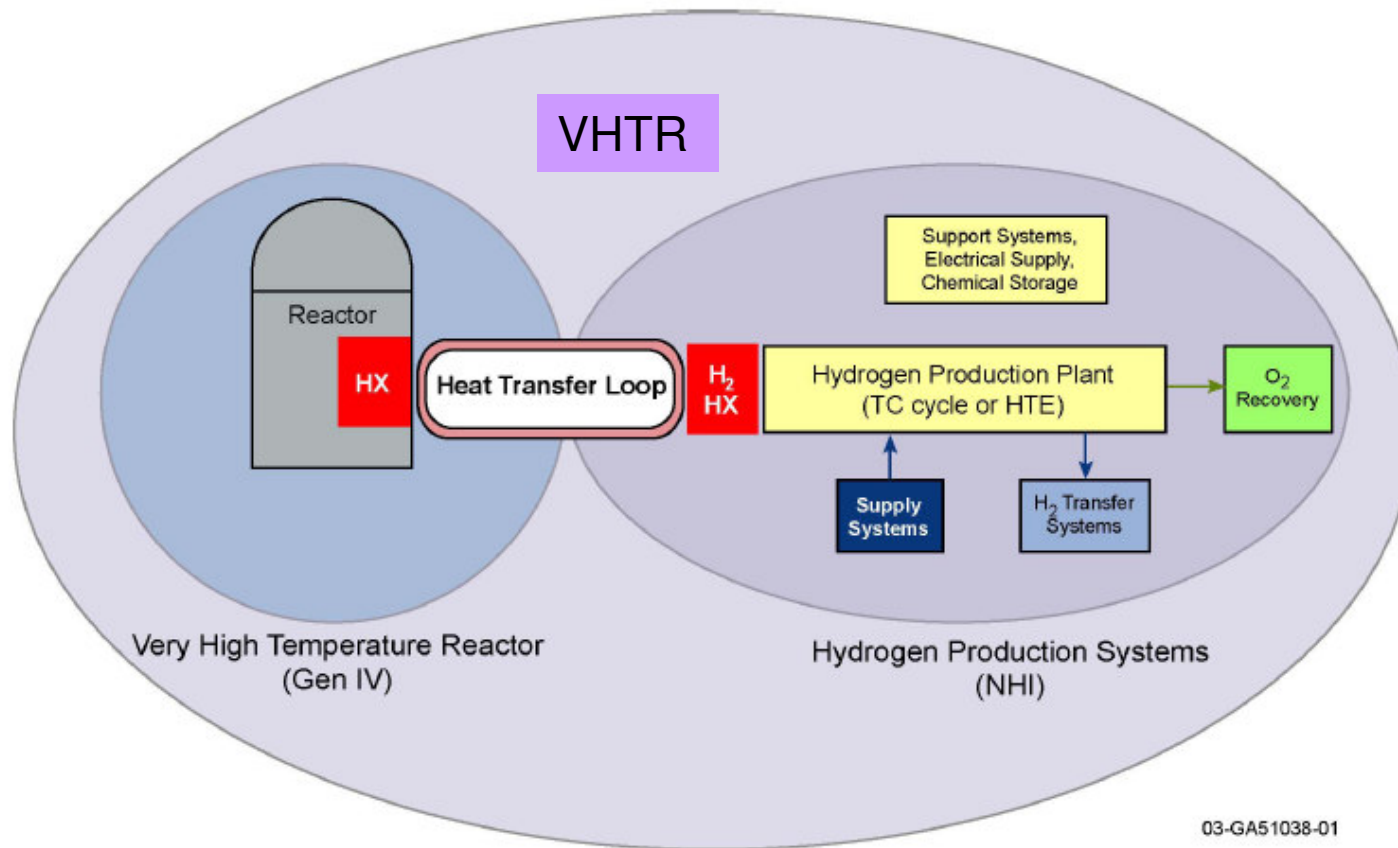

Satyen Baidur  
Ottawa Policy Research Associates  
CNS Ottawa Chapter January 24 2008



# Master Logic Diagram for Hydrogen Disruption Scenarios (Smith 2006, INL)

SAPHIRE

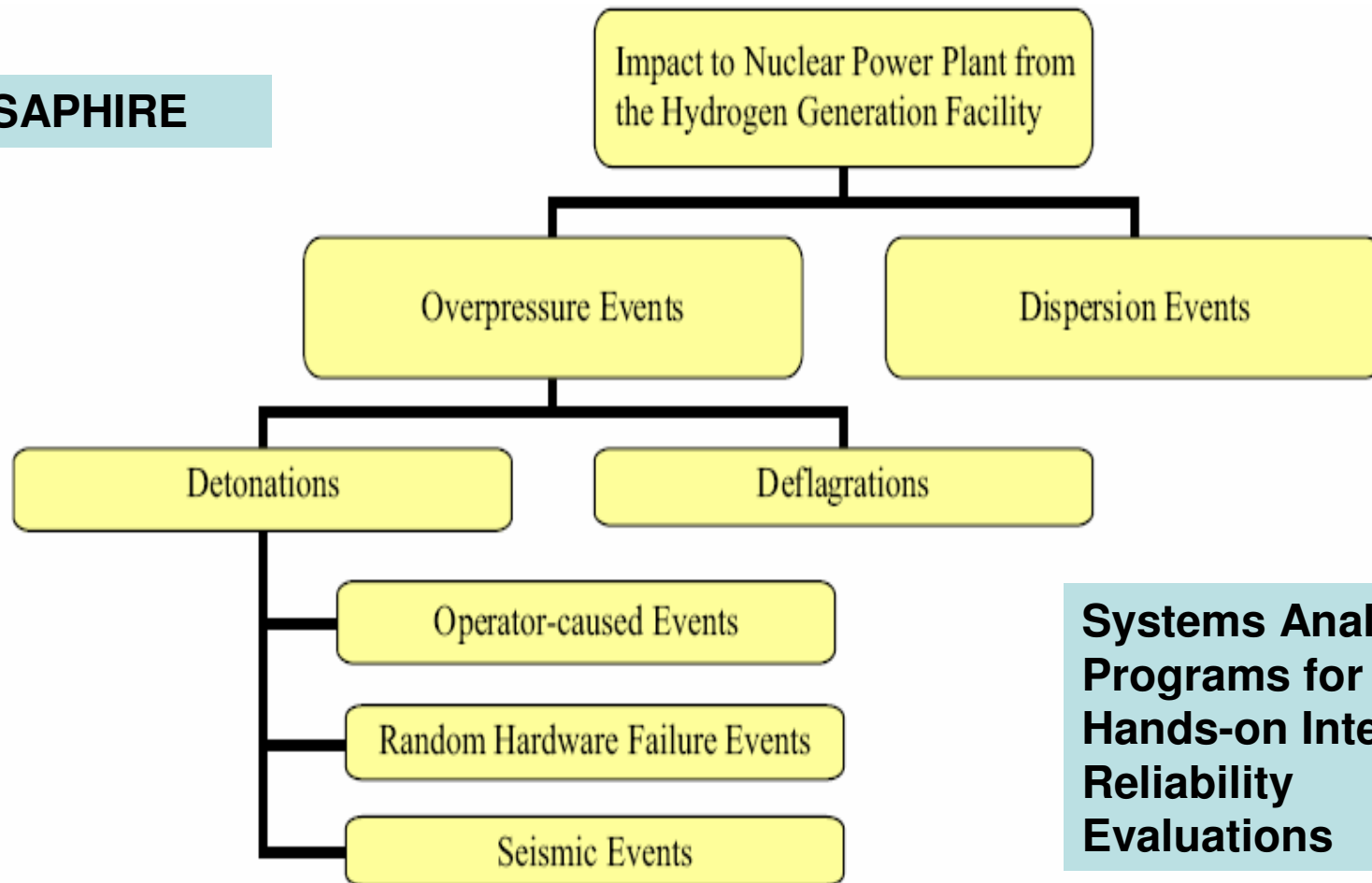

**Systems Analysis Programs for Hands-on Integrated Reliability Evaluations**



Satyen Baindur  
Ottawa Policy Research Associates  
CNS Ottawa Chapter January 24 2008



# Conditional Probability of an Explosion Given a Hydrogen Leak

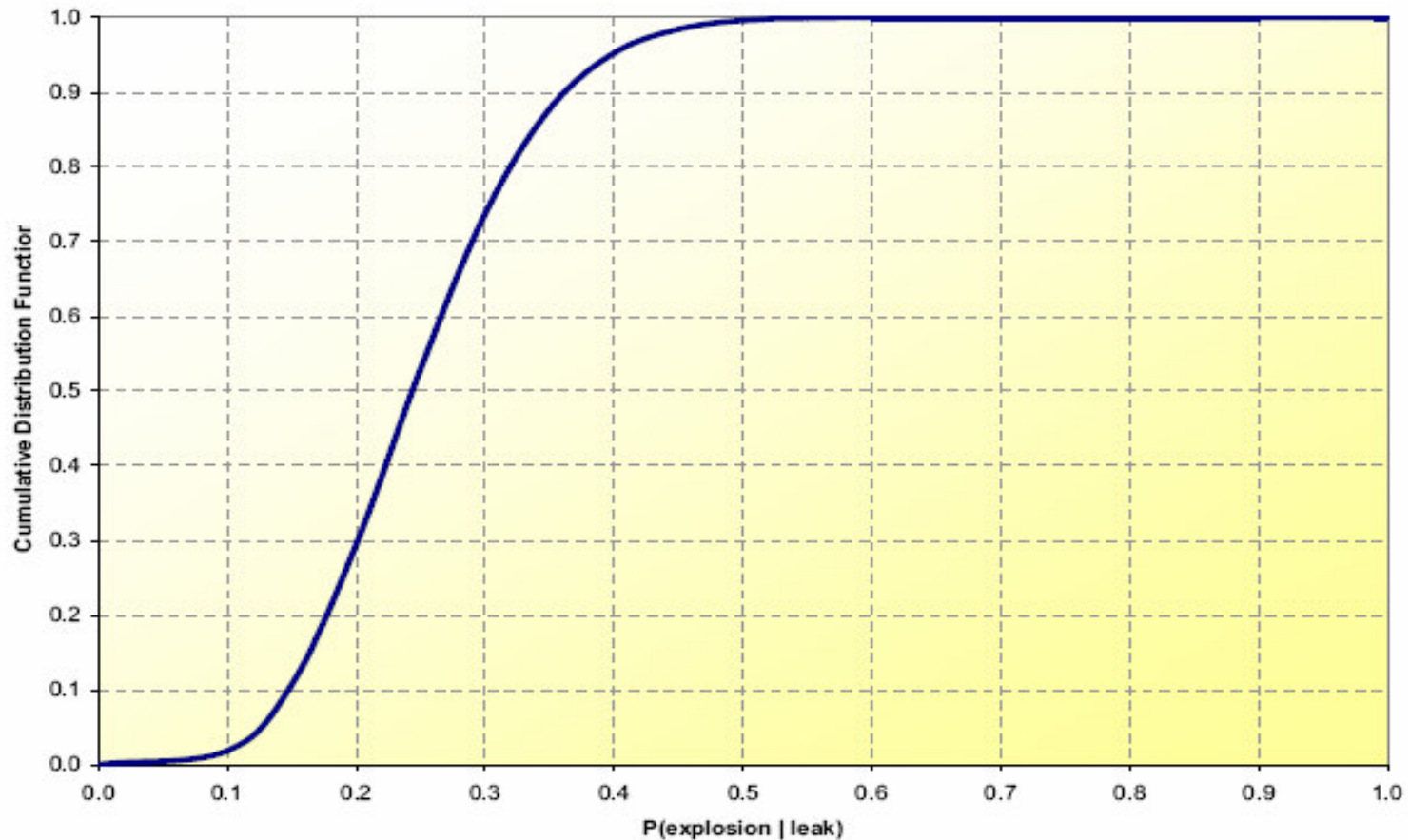

History + Physics-based model

25% of Leaks resulted in Explosions



Satyen Baindur  
Ottawa Policy Research Associates  
CNS Ottawa Chapter January 24 2008



# 1. Separation Distance between Nuclear and Thermochemical Plants

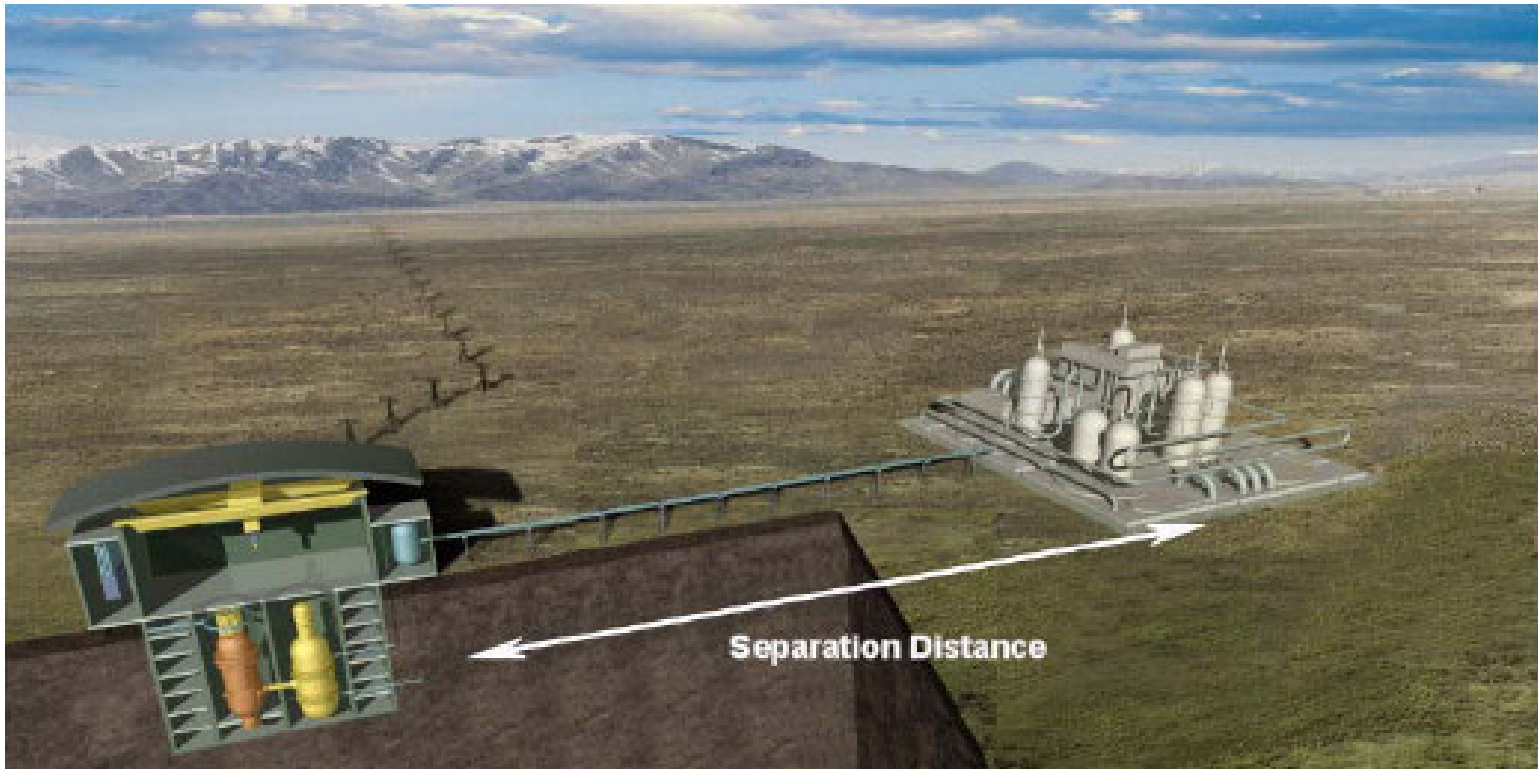

**C. Smith, S. Beck and W. Galyean**, “Separation Requirements for a Hydrogen Production Plant and High Temperature Nuclear Reactor”, INL-EXT-05-00137, October 2006.



Satyen Baidur  
Ottawa Policy Research Associates  
CNS Ottawa Chapter January 24 2008



# Core Damage Risk as a Function of Separation Distance

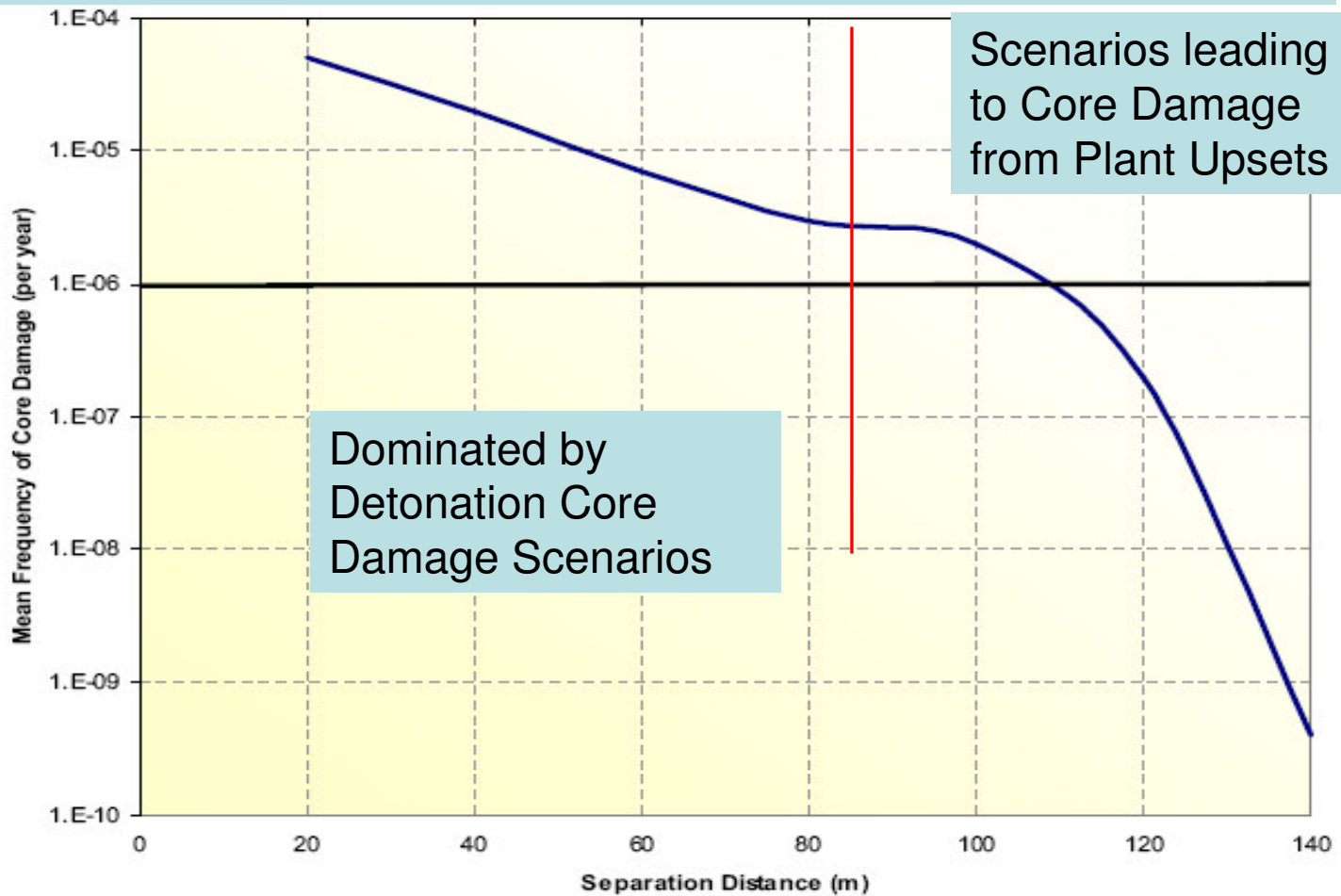

Satyen Baidur  
Ottawa Policy Research Associates  
CNS Ottawa Chapter January 24 2008



## Summary of Case Studies (Smith, Beck, Galyean 2006)

Case	Description	Mean Core Damage Frequency (per year)	Mean Chemical Dispersion Frequency (per year)
Nominal	No mitigating features and the separation distance set at 60 m	7E-6	3E-3
1.	Varying the separation distance between the nuclear and hydrogen production facilities	Figure	3E-3
2.	Constructing an earthen barrier between the nuclear and chemical facilities	4E-10	3E-3
3.	Constructing the nuclear facility primarily underground	4E-10	3E-3
4.	Constructing blast panels near the chemical facility to dampen overpressure events	4E-10	3E-3
5.	Constructing the chemical facility primarily underground	8E-11	8E-4
6.	Moving the nuclear plant control room offsite	7E-6	Releases no longer impact control room



Satyen Baidur  
Ottawa Policy Research Associates  
CNS Ottawa Chapter January 24 2008



# Potential Arrangement of 600 MW VHTR for H<sub>2</sub> Production

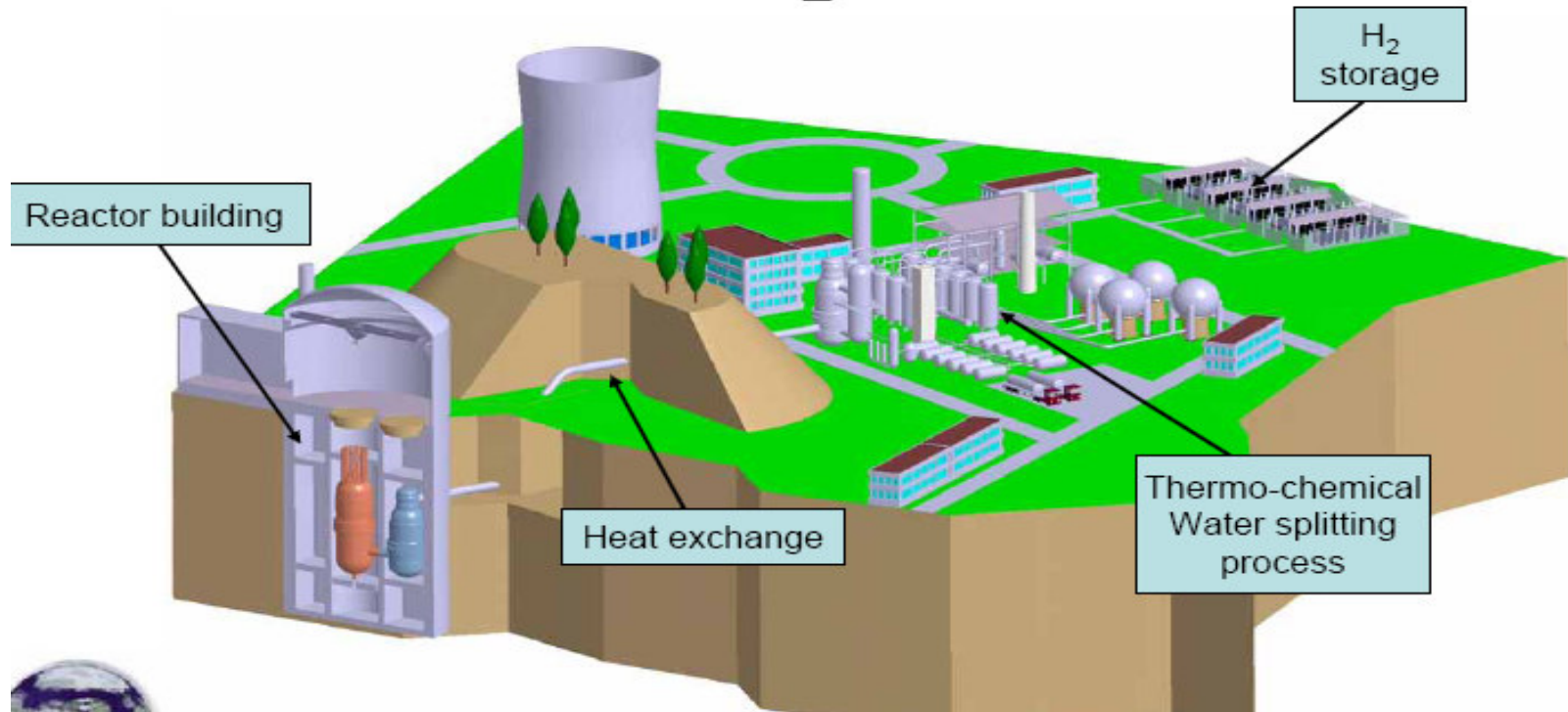

Verfondern (2006)



Satyen Baidur  
Ottawa Policy Research Associates  
CNS Ottawa Chapter January 24 2008



## INL Study Recommendations Regarding Nuclear Hydrogen Plants

Other recommendations from the INL study include:

- A 100 kg on-site limit for Hydrogen storage.
- Quickly Pipe out as produced.
- Use of double-walled pipes for hydrogen transport
- Location of the nuclear plant control room outside of the dispersion zone for chemical release.



Satyen Baindur  
Ottawa Policy Research Associates  
CNS Ottawa Chapter January 24 2008

